

MRA-M

Quick Air Valve

Small body Big air release for water pipeline



1. Trusted air release feature meets JWWA B137 Quick Air Release Valve Standard.
2. Compact and light body enables ease of handling
3. Corrosion resistance with selected parts made of stainless steel and synthetic resins
4. Built-in ball valve for quick maintenance without removing the valve off the pipeline
5. Optional anti-freeze jacket for low temperature regions



Maizawa Industries, Inc.

SPECIFICATION

Nominal size : DIA 25mm

Fluid type : Potable water, clean water

Working pressure : 0.75MPa (type2), 1.0MPa (type 3)

STRUCTURE

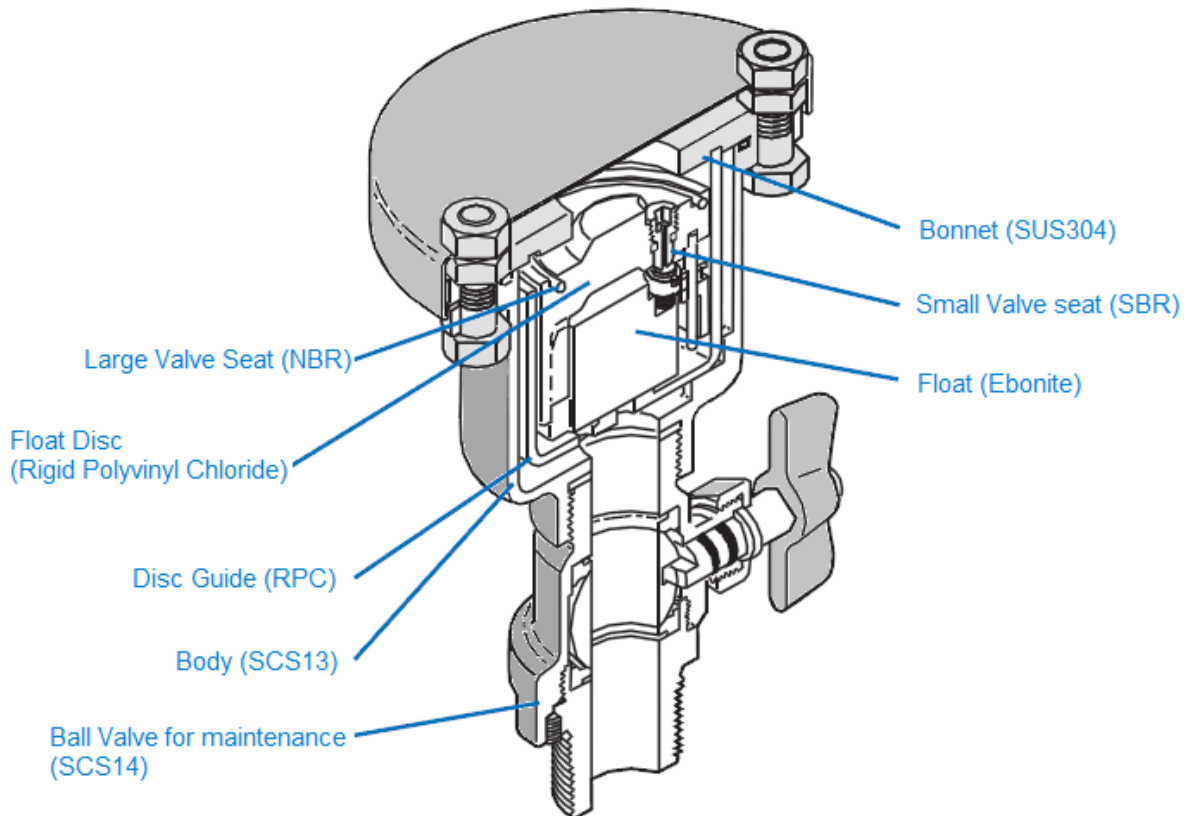

HIGH AIR RELEASE CAPACITY

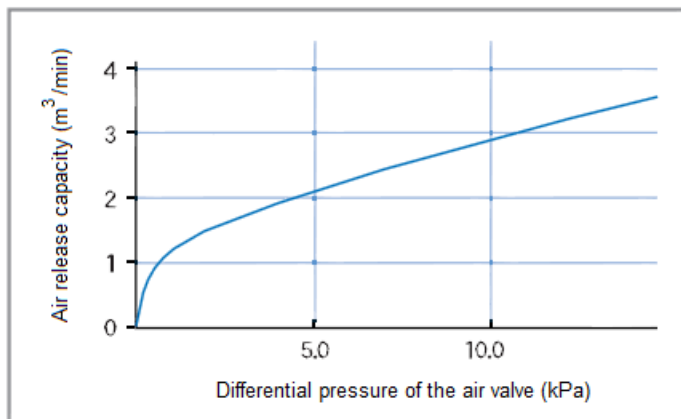

DIMENSION

Regular model

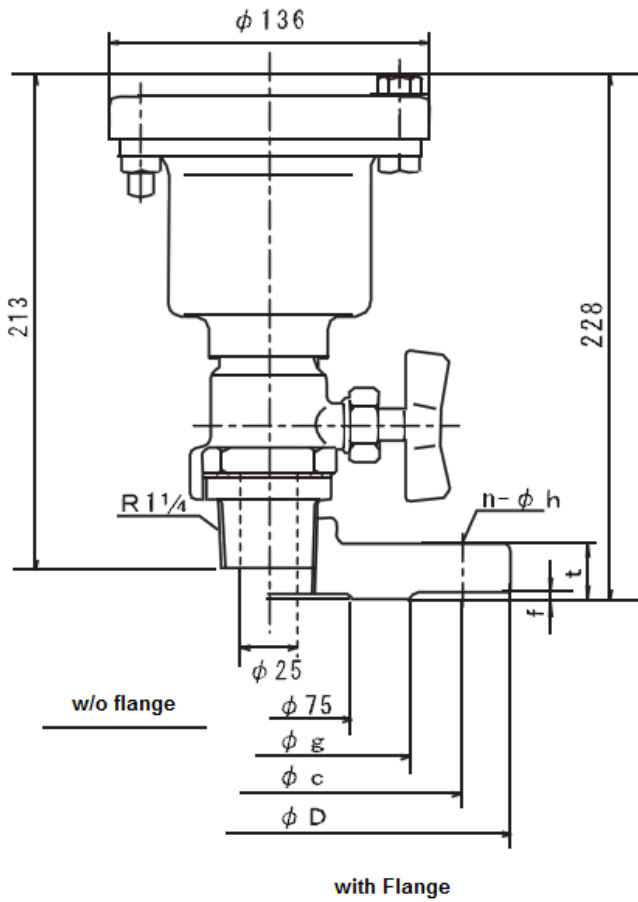

Anti-freeze model with Jacket

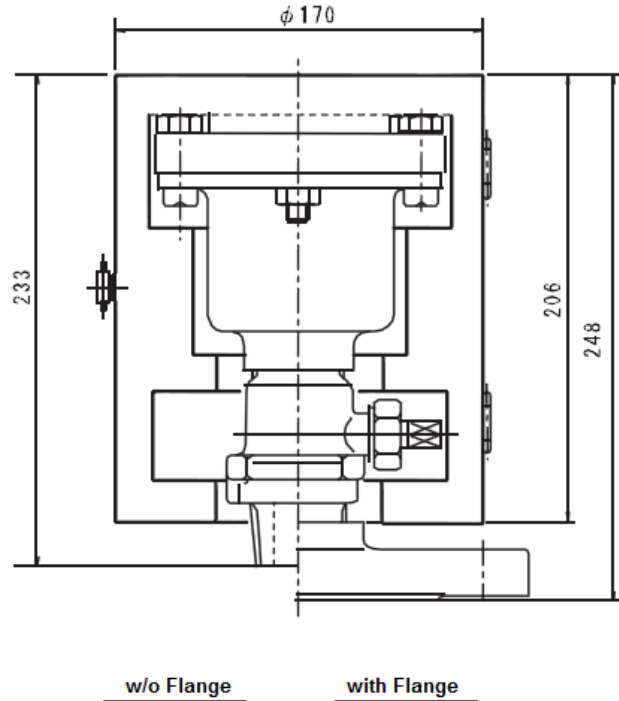

Unit : mm

	D	g	c	n	h	t	f
Type 2	211	125	168	4	19	22	3
Type 3	185	126	150	8	19	18	2

Any information in this document is subject to change without notice.



Maezawa Industries, Inc.

5-11 Nakacho, Kawaguchi-city, Saitama 3328556 JAPAN

TEL : +8148-251-5511

FAX : +8148-251-9375

<http://www.maezawa.co.jp>



ISO 9001



ISO 14001