

Aqua Tech



水のマイゼフ

NO. 61e

EMERGENCY SHUT-OFF VALVES ESOV

Reliable automatic feature for second disaster prevention

Type MTB

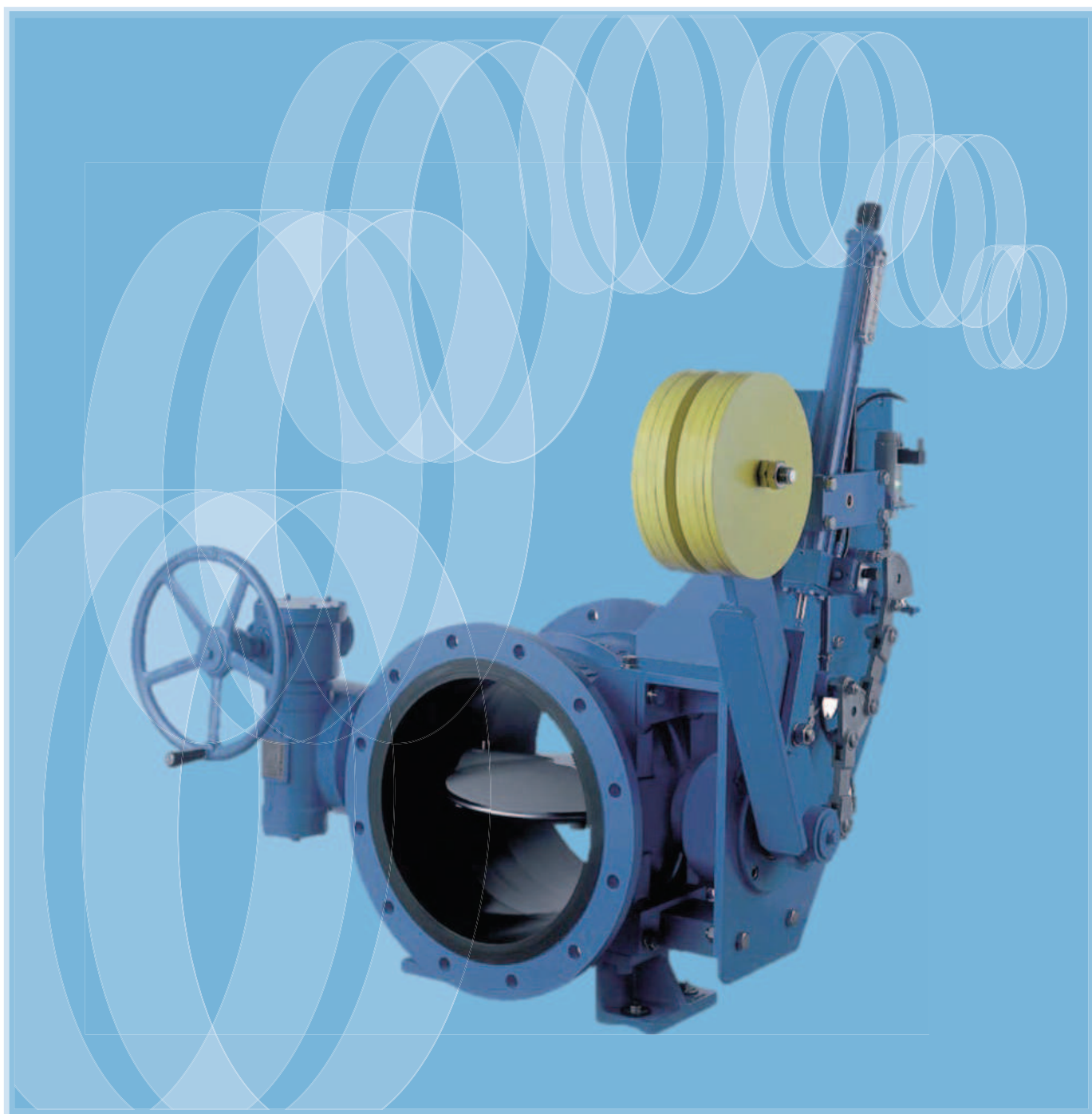

Maezawa Industries, Inc.

Securing life water supply lines

1. Reliable shut-off/open feature using gravity on weight.
2. Automatic lock and release with multiple leverage structure to ensure perfect lock & unlock with minimum trigger power.
3. Slowing shut-off speed with dumper and braking system to avoid being damaged by water hammer.
4. Optional sensors for variety of trigger applications.
5. Operation under blackout with optional power supply.
6. The position retainer holds the valve at any position enabling activation check without shutting down the flow.

Main materials and Standard specification

Main materials

Body	FCD450-10
Disc	FCD450-10
Seat on Body	Synthetic rubber
Stem	SUS420J2
Locking device	SCS13 or SUS304

Standard specification

Valve Standard	JWWA B 138
Face-to-Face Dimension	JWWA B 138
Flange Type	Conform to JIS G 5527
Design Pressure	0.75MPa
Design Pressure(weight)	0.15MPa

Variety of sensing methods

A) Earthquake Sensing

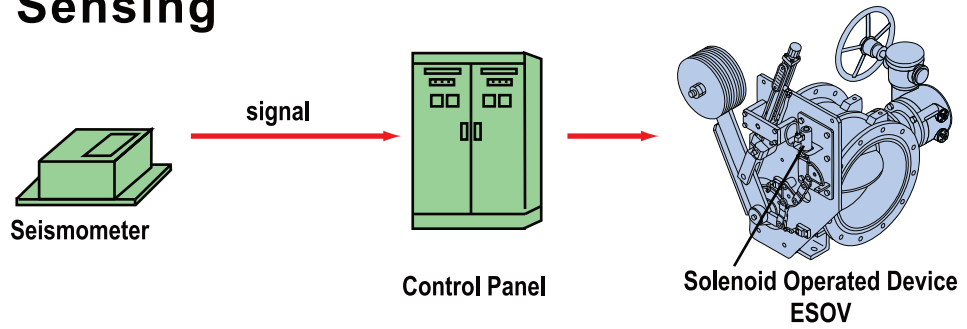

B) Flow velocity Sensing 1

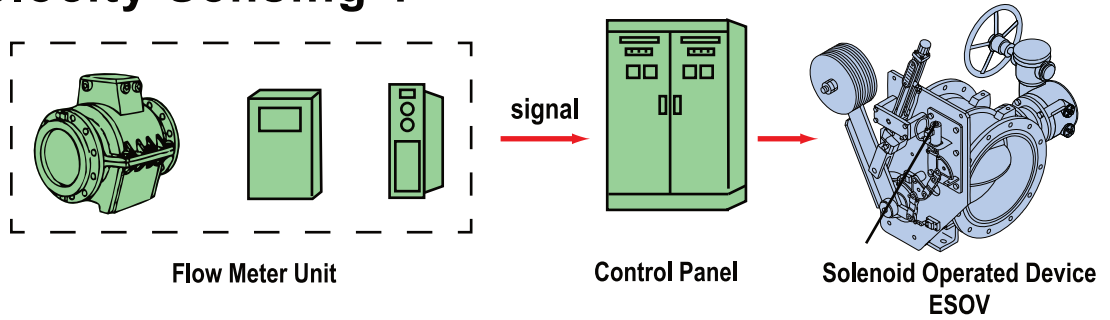

C) Flow velocity Sensing 2

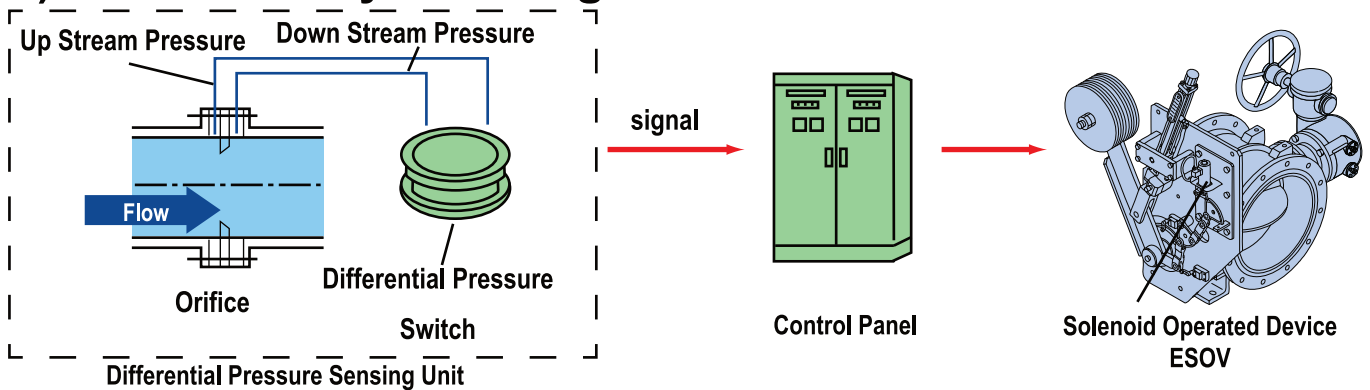

D) Flow velocity Sensing 3

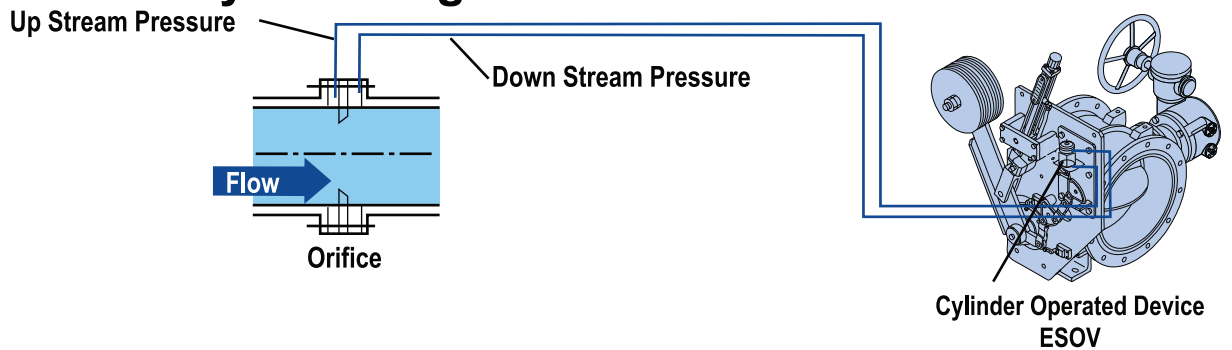

E) Flow velocity Sensing 4

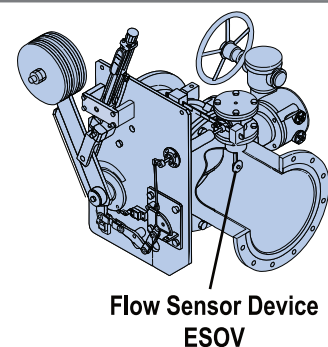

Solenoid / Cylinder Operated Type

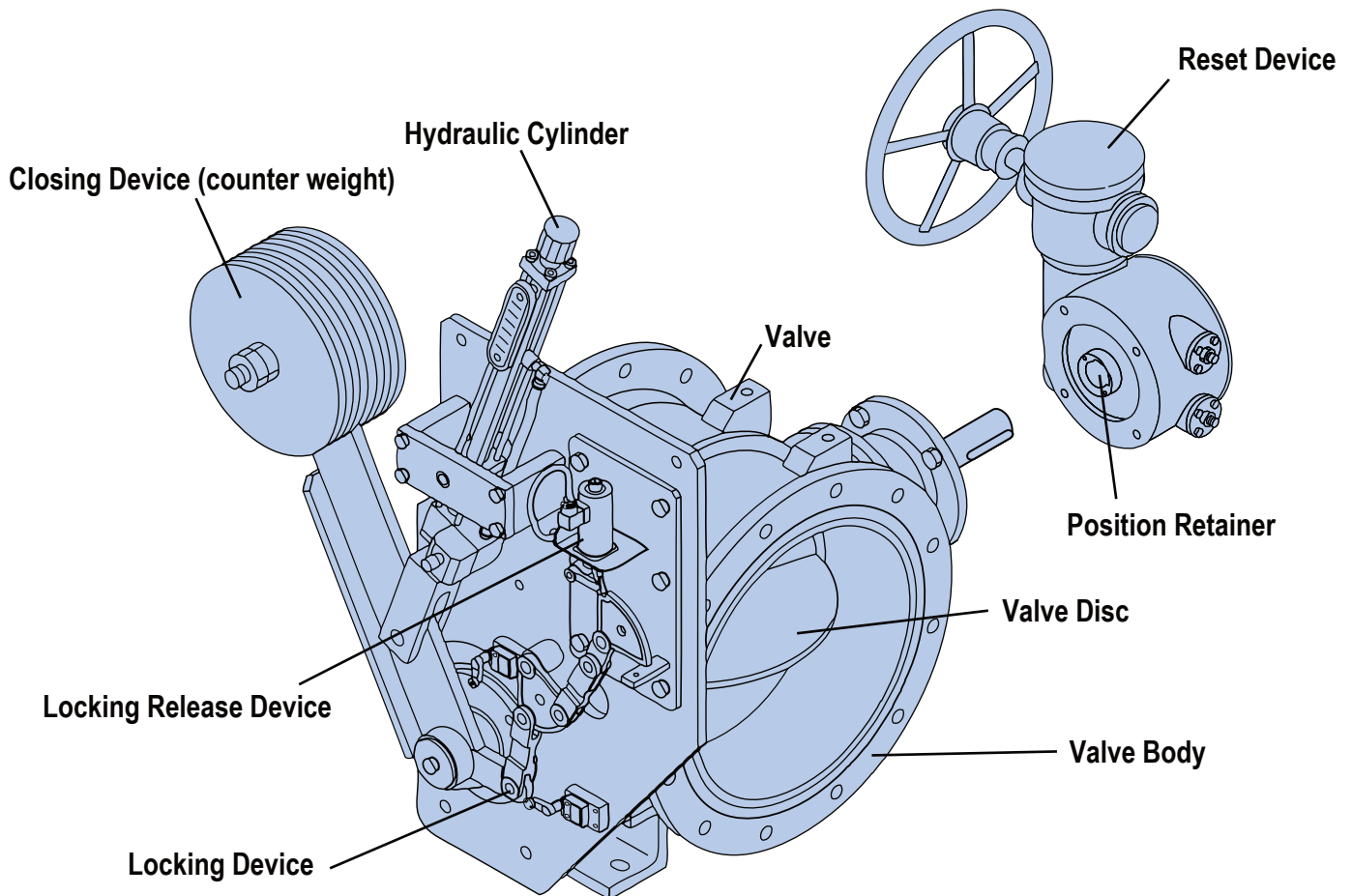

Valve

The valve is always at full-open position, and it will be fully closed in time of emergency. The valve is conforming to the JWWA B 138 standard,

Locking release device

The valve is set to the full-open position as default and will be released to the closing position in case of emergency.

Locking release device has two types; solenoid operated and cylinder operated.

Hydraulic device

The valve closing speed is adjustable at any desired value by hydraulic device to prevent the water hammer and negative pressure.

Closing device

In case of emergency, valve shall be closed by a gravitational potential energy.

Reset device

Once the ESOV has been closed, it can be resumed to the open position manually / electrically and will be retained at the designated position by the position retainer.

Flow Sensing Type

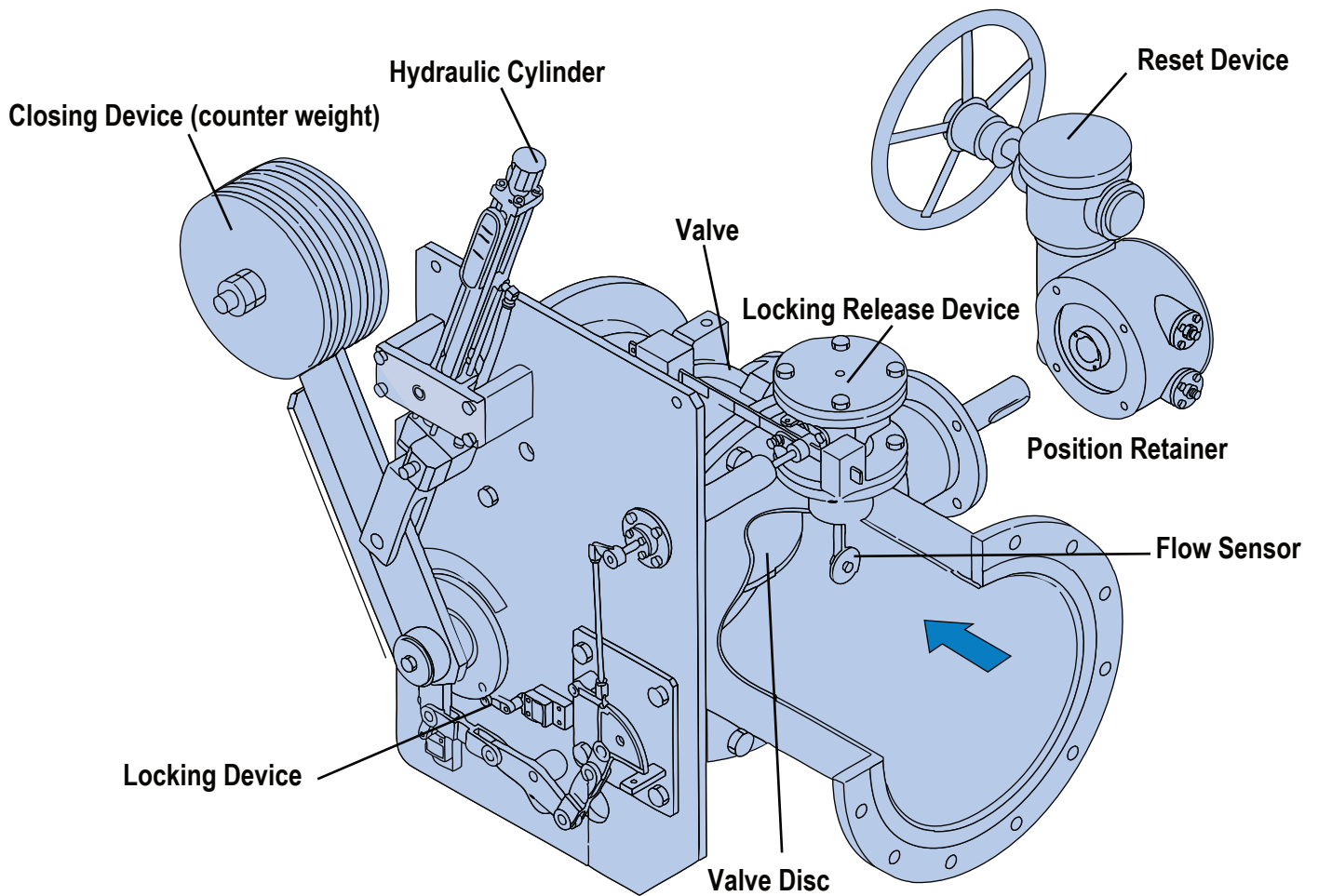

Valve

The valve is always at full-open position, and it will be fully closed in time of emergency. The valve is conforming to the JWWA B 138 standard,

Locking device

The valve is set to the full-open position as default and will be released to the closing position in case of emergency triggered by the flow sensor placed at upstream side.

Hydraulic device

The valve closing speed is adjustable at any desired value by hydraulic device to prevent the water hammer and negative pressure.

Closing device

In case of emergency, valve shall be closed by a gravitational potential energy.

Reset device

Once the ESOV has been closed, it can be resumed to the open position manually / electrically and will be retained at the designated position by the position retainer.

Dimensions

Solenoid / Cylinder Operated Type

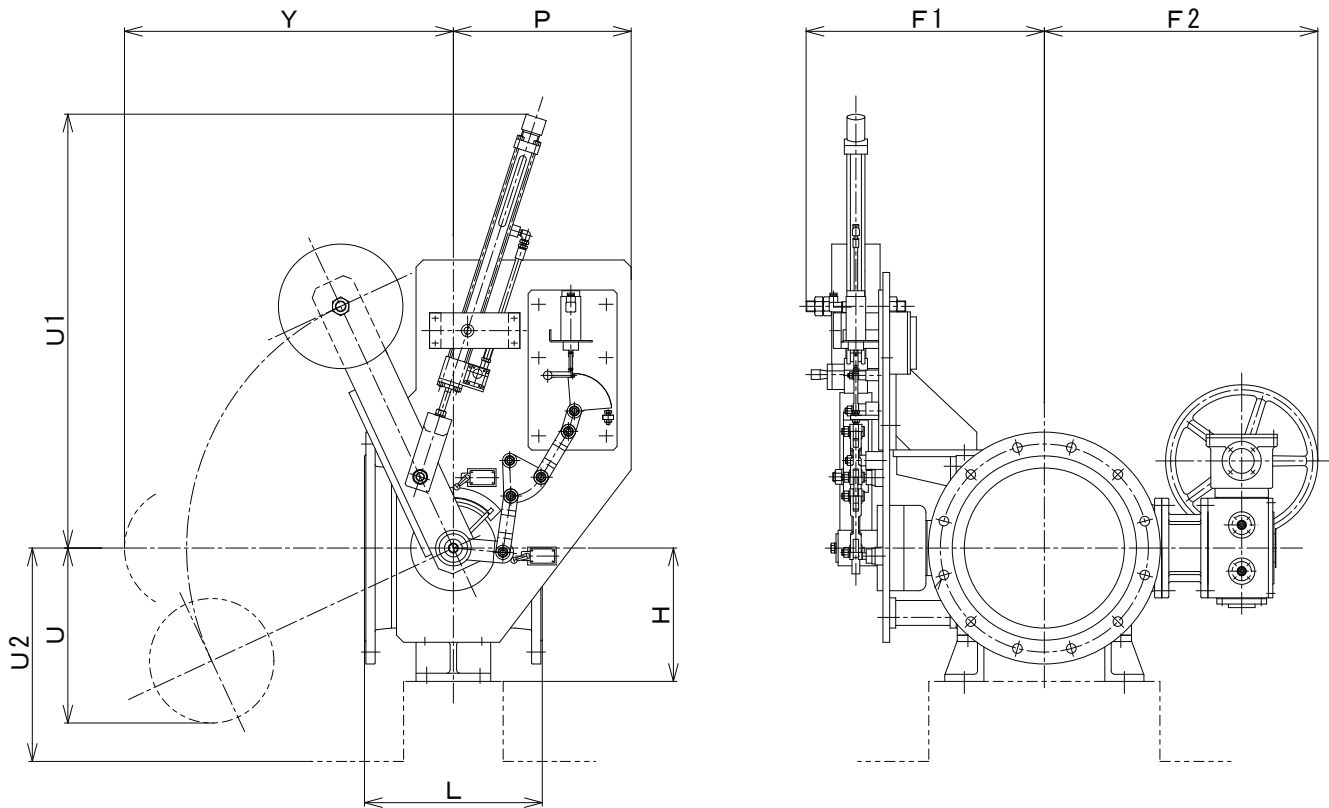

(Note: For size over $\phi 350$ mm, Handwheel will be placed on top of the gear box.)

(Unit : mm)

Symbol Size(d)	L	H	F1	F2	Y	U	U1	U2	P
150	280	170	395	533	530	315	900	400	350
200	300	200	428	563	530	315	900	400	350
250	380	240	467	568	690	415	985	500	350
300	400	270	515	573	690	415	985	500	350
350	430	300	545	643	690	415	985	500	350
400	470	350	635	734	925	492	1220	600	500
450	500	375	670	769	925	492	1220	600	500
500	530	400	700	819	925	492	1220	600	500
600	560	450	780	943	925	492	1271	600	500
700	610	500	943	1158	1030	710	1155	800	700
800	690	550	993	1170	1130	790	1261	900	720
900	740	600	1123	1260	1230	855	1417	950	720
1000	770	650	1193	1462	1330	920	1417	1000	760

Application Examples

1. Preventing an outflow from Distribution Reservoir using a Seismometer.

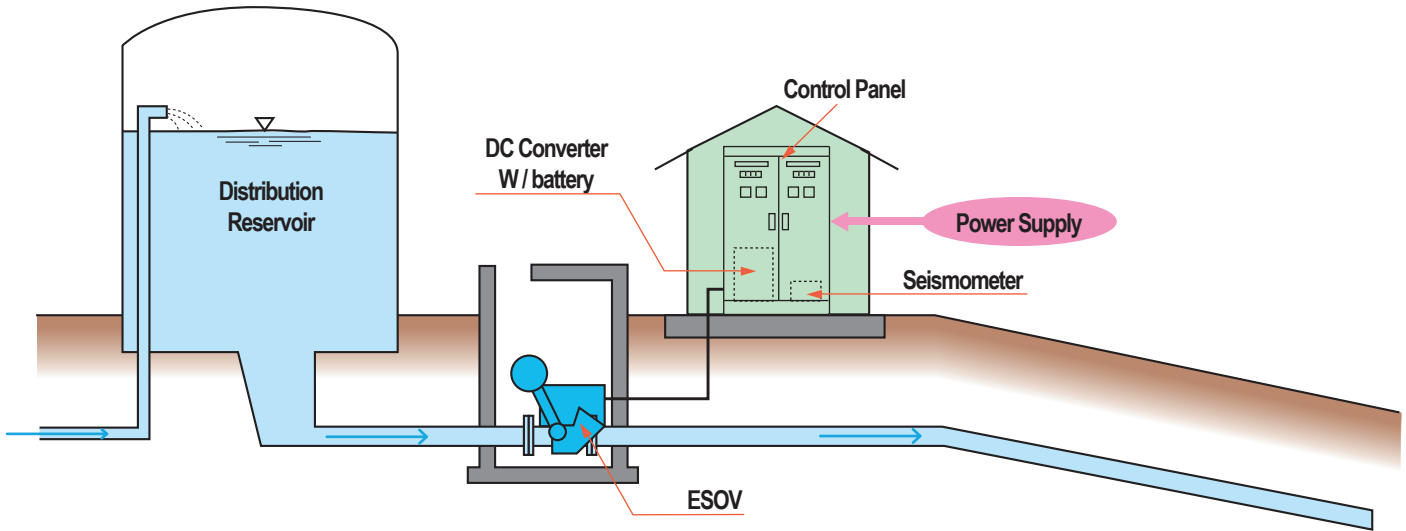

2. Preventing an outflow from Distribution Reservoir using a flow Sensor.

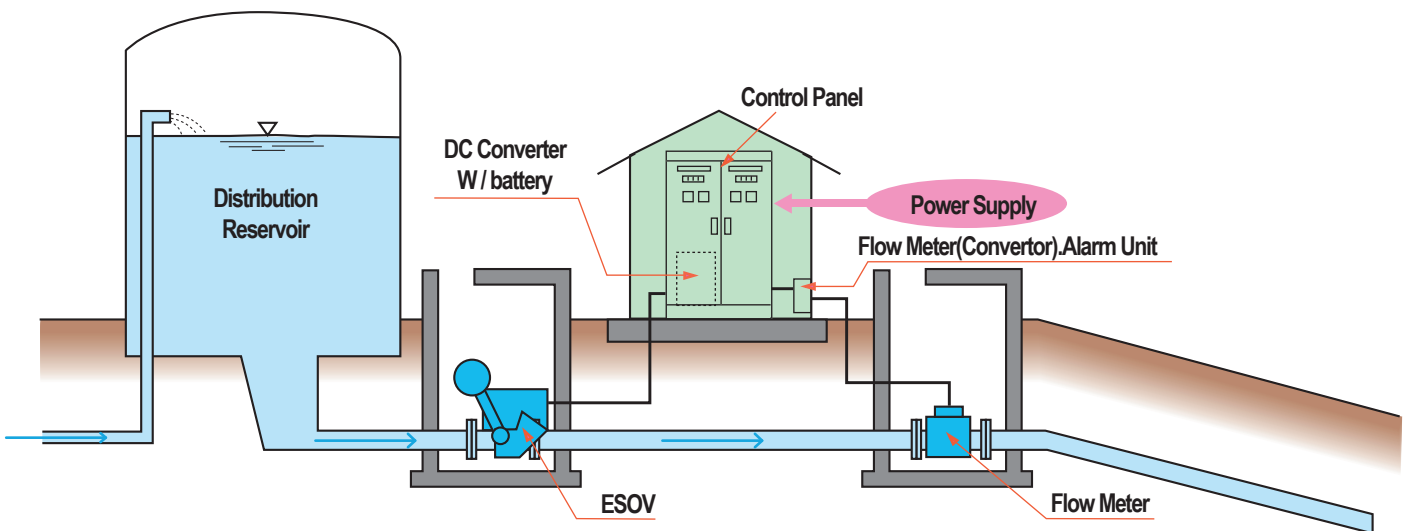

3. Abnormal Flow Detection using differential pressure and built-in cylinder device.

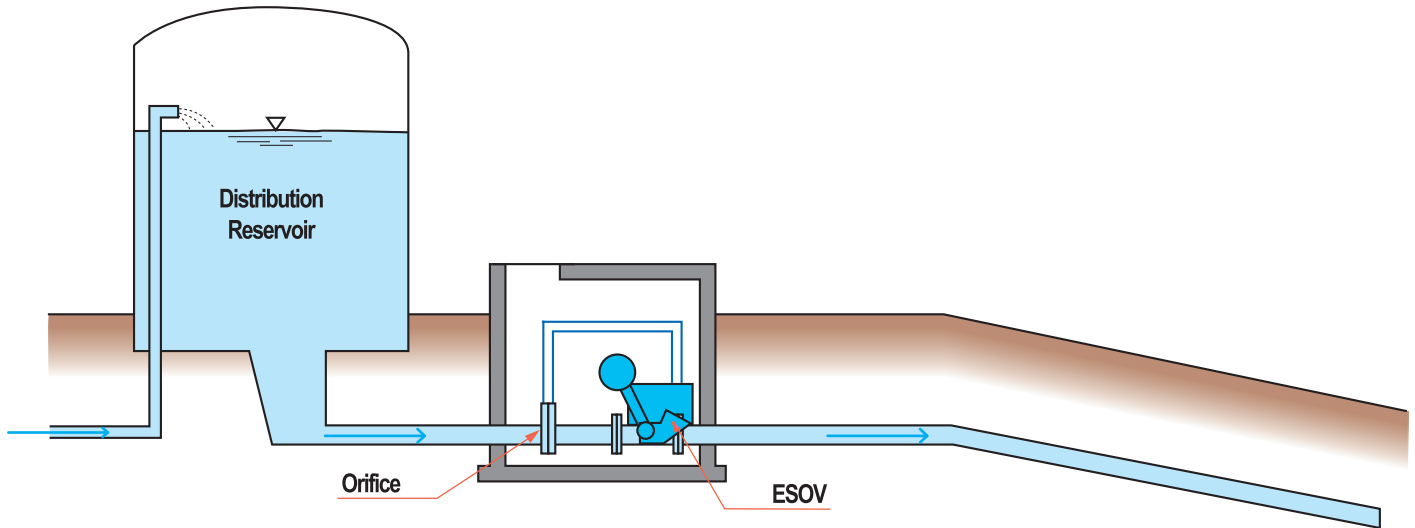

4. Abnormal Flow Detection using a built-in flow sensing mechanism.

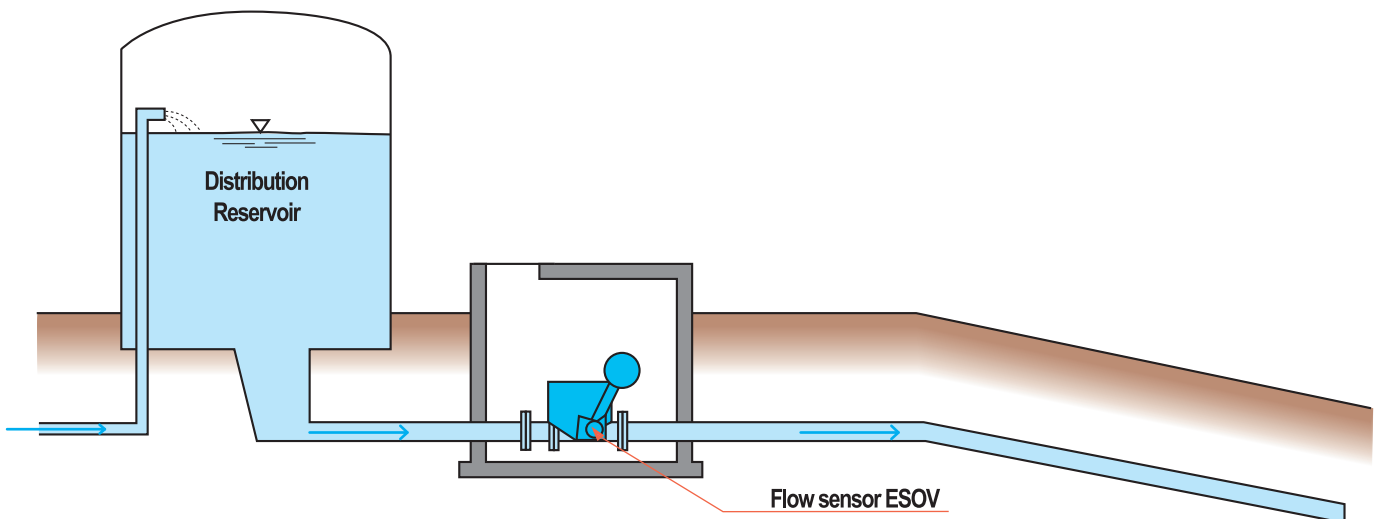

Any information in this document is subject to change without notice.



Maezawa Industries, Inc.

5-11 Nakacho, Kawaguchi-city, Saitama 3328556 JAPAN

TEL: +8148-251-5511 FAX: +8148-251-9375

<http://www.maezawa.co.jp>



61e '22.01 X 01 (IBD)